

SB2t

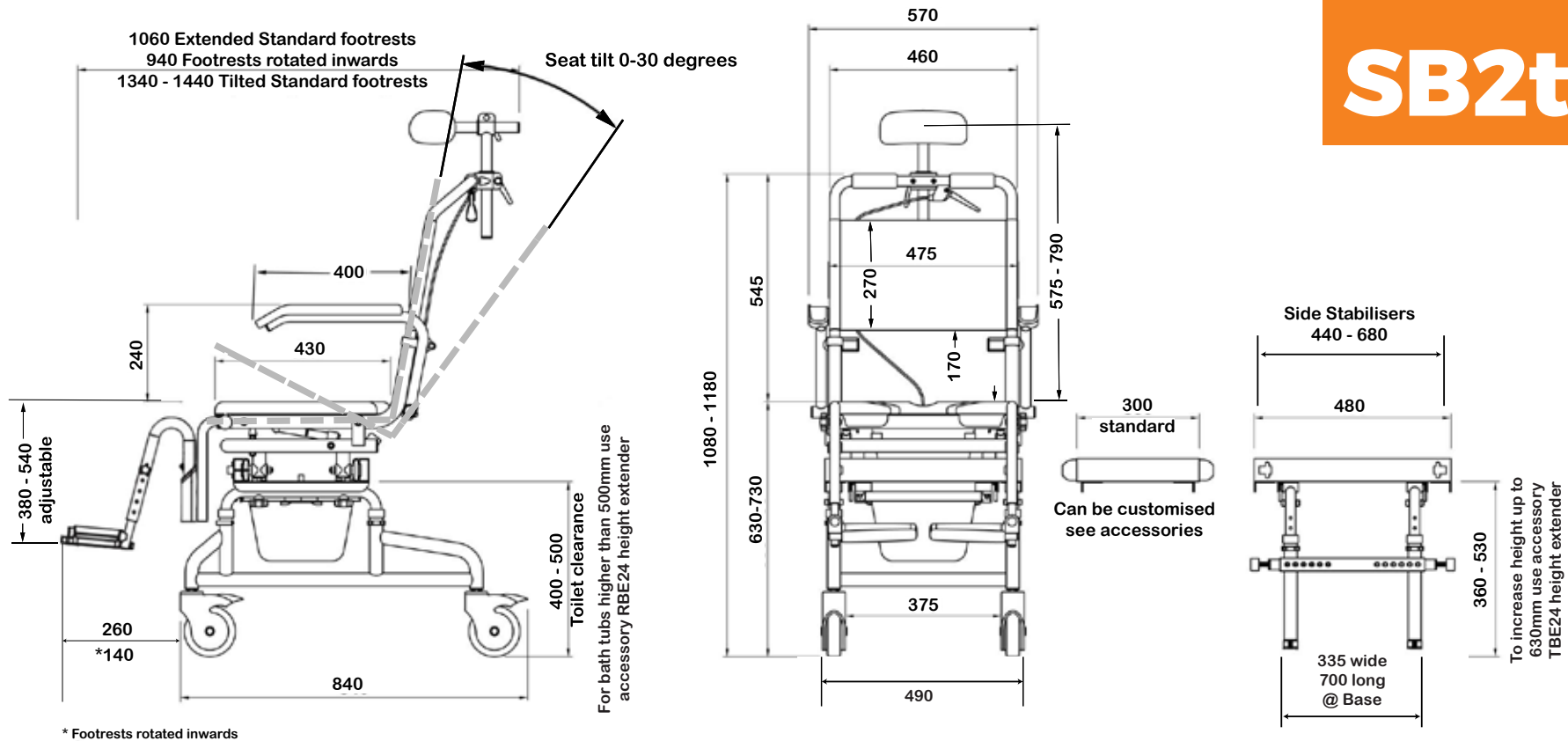

* Footrests rotated inwards

Product features:

- Weight capacity - 250kg
- Tilt angle 0 - 30 degrees, infinite positioning
- Rolls over most standard toilets
- Low maintenance
- Arms - removable / lockable / flip-back
- Height adjustable
- Safety mechanisms & side stabilizers on bath base
- Footrests - removable and swing-away
- No rust aluminum frame (Grade 6061 T6)
- Stainless steel parts and hardware (Grade 304)
- Safety belts - lap & chest belts plus calf strap
- Caster Wheels - 125mm x 4 locking
- Commode system
- Neck rest, fully adjustable
- Tool-free assembly
- Full details see page 32-36

Accessory items

- Refer to the accessory pages or on our website

easyCare
systems

www.easycare.co.uk