

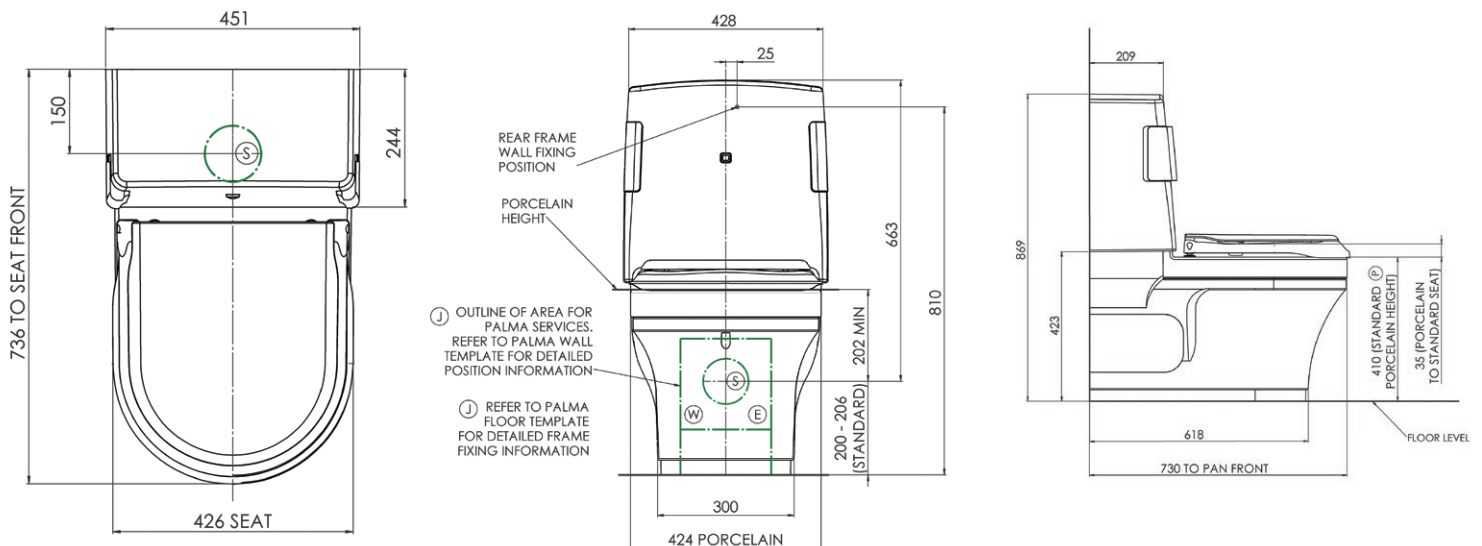

Palma Vita wash & dry (shower) toilet



- Safe working load:  190kg 30St
- Overall dimensions: 869mm high x 451mm wide x 730mm deep

The Closomat Palma Vita has been purpose-designed to combine a conventional WC with integrated washing and drying. It is the only toilet of its kind, specifically developed for elderly and disabled people, that is designed to properly support the user AND position them correctly for effective washing and drying.

Features:

- Combines functions of a WC and bidet with addition of drying air
- Simultaneous flushing and washing (a unique feature)
- Simple 'hands free' action automatic flushing, warm water washing and warm air drying
- Removes hand/body contact and risk of faecal contamination
- Can be used by all members of the household
- Unique ^{one}touch system allows the user to benefit from the toilet's automatic functions by just pressing and releasing the elbow pad
- Full installation and service & maintenance packages are available
- Pan connector will work with S or P Trap, left or right hand (not supplied)
- 15mm cold water supply from mains or storage vessel ('Grey Water' must not be used)
- Flow rate - 8 litres/minute
- Safe working load: Palma Vita 190Kg/30St, Bariatric Palma Vita increased to 362Kg/57St
- Compliant with current Electrical Regulations - Can be fitted in Zone I of a bathroom/wetroom
- Only wash & dry toilet that can be adapted to accommodate user's changing needs
- Can be personalised to individual requirements
- UK design and development • UK manufacturing • UK customer support



Accessories:

- **Plinth (25, 50, 75 & 100mm heights)** - Used to raise the whole unit for users of shower chairs or to aid direct wheelchair transfer
- **Integrated fold down support arms** - For additional assistance of wheelchair users
- **Soft arm sleeve** - Comfortable, hygienic and stylish dimension to the integrated fold down support arms
- **Lateral body supports** - Provide extra support and stability to the user, in conjunction with the integrated fold down support arms
- **Soft seat, junior** - Dark blue colour, to aid the visually impaired
- **Soft seat, adult** - Dark blue colour, to aid the visually impaired
- **Soft seat, adult open fronted** - Dark blue colour, to aid the visually impaired
- **Alternative douche arms** - Single Extended and Twin Spray
- **Infra-red remote control** - Wireless 'Push and go' control
- **Touch sensitive hand/foot switch** - Alternative for those users who are unable to use the standard elbow pads
- **Proxy switch** - For users with little or no grip to activate the unit by passing their hand/body part in front of the sensor
- **Infill Panel** - Designed to aid installations where pipe-work inhibits the Palma Vita from being located against the wall. Available in thickness sizes 25, 50 & 75mm