

closomat®



Closomat Palma Vita installation & user guide

design • manufacture • supply • install • service • recycle

Technical data

The Closomat toilet **MUST** be installed by a competent or qualified person.

Explanation of symbols

- Safety instructions in this manual are identified by symbols. The safety instructions are introduced by signal words, which express the extent of the hazard/risk.
- In order to prevent accidents, personal injury, property damage and guarantee maximum user safety, follow the safety instructions without fail and exercise caution.

Description of equipment

- The Closomat toilet is an electrically operated shower (wash and dry) toilet designed to provide the operator/user with a hygienic solution to toileting.

Start-up procedure

- To enable a warm washing cycle operation the Closomat toilet must be switched on. Each Closomat toilet has its own isolation switch. To switch the unit on, locate the switch on the right hand side of the unit at the base of the cistern cover, through a Perspex screen.
- Once switched on, the water will reach core temperature within 5 minutes. It is advised that to maintain the core temperature in readiness for use, the unit be left switched on at all times.

Electrical services

- To avoid the risk of electric shock, this equipment **MUST** only be connected to a supply mains with protective earthing by a competent or qualified person.

Mains isolation

- All electrical appliances must be installed in accordance to the relevant regulations associated with the country it is within. To conduct any form of repairs or servicing it is recommended that a mains isolation device be located in the vicinity of the unit.
- 220-240V single phase AC supply is required, (loading 4.5A-4.9A, maximum power 1300 watts). The Closomat toilet is supplied with a 3 core cable attached and **MUST NOT** be removed or replaced. A 10A fused spur is required for isolation.
- Spur outlet to be located in accordance with current I.E.E. Regulations (Current Edition).
- No modification of this unit is allowed other than by the manufacturer.
- **Closomat has IPX4 rating.**

Shutdown procedure

- For normal isolation, the Closomat toilet can be turned off using the integrated switch. To carry out any servicing, the unit **MUST** be isolated at the mains feed.

Bathroom/shower room installations

- The Closomat toilet must not be in direct line with the shower spray. Some form of partition between shower and the Closomat toilet is advisable to prevent any water spraying directly onto the equipment.
- A shower should not be used in conjunction with the Closomat toilet i.e. under no circumstances must a user shower whilst seated on the Closomat toilet.

Water services (WRAS approved)

- **It is essential that the entering water is cold.**
- We would recommend water supply isolated via isolation valve.
- Water supply can be from storage vessel or mains ('Grey Water' **MUST NOT BE USED**).
- Boiler Capacity: 1.7 litres.
- Water rate: min. 8 l/min.
max. 0.8 MPa (8 bar)
- Cistern capacity: 6 litres.

Overflow

- The Closomat toilet has an internal overflow which discharges into the W.C. pan through the flush valve.

Soil connection

- Relevant soil connector to be sourced by installer.
- Soil connections suitable for Closomat toilet; S-Trap (vertical fall) wall to centre of pipe from 70mm-230mm max. P-Trap (horizontal) floor to centre of pipe 200mm max.
- The Closomat toilet is suitable for all turned trap outlets, through purpose made removable side covers on lower level.

Further notes

- No permanent hand rails or other obstructions should be fitted across the front or top of the unit. The outer casing has to be pulled upwards and forward to remove for servicing purposes.
- Unit not rated for altitude. 2000m is the maximum.
- This application requires an earth connection.
- Environmental conditions – operating ambient room temperature maximum = 40°C.

Environmental conditions

The Closomat toilet is rated to IPX4 and can be installed and operated within a typical shower/toilet room.

Infill panel

The infill panel specifications are printed on page 11.

Classification

Low Voltage Directive BS EN 60335-2-84.

Cleaning information

- The use of bleach products is not advised due to the exposed stainless metal parts associated with the washing device. (tarnishing may occur).
- The Closomat toilet washing device is designed to self cleanse during and after every use. Normal cleansing of the bowl and outer covers is required.

Maintenance and frequency of serviceable parts

- The Closomat toilet is self-sufficient but it is recommended that a competent experienced Service Engineer carry out a safety check and an annual service of the internal workings, to extend the Closomat's life.

Risk associated with the waste of equipment after service life

- At the stage the unit is not repairable it can be discarded to any appropriate recyclable plant. There are no immediate risks to the environment.

User guide

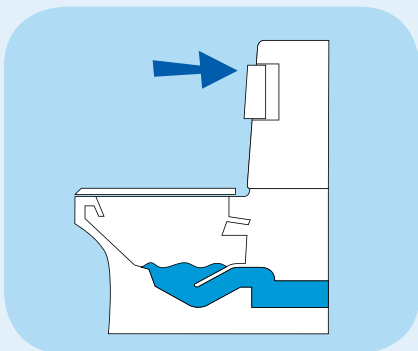

Flushing

Press either elbow pad whilst standing for conventional flush.



Washing

Press elbow pad whilst seated and hold down for approximately 10-15 seconds, flushing and warm water washing will then take place.

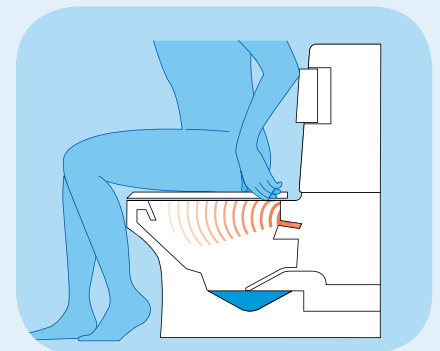

Drying

Warm air drying automatically follows when elbow pad is released.

Palma Vita planning data and service requirements

Key / Installation guide:

1. Determine unit height as standard or with optional points (P)
2. Locate floor & wall template jig to plan positions (J)
3. Locate waste pipe / soil position (S)
4. Locate cold water supply (W)
5. Locate electrical supply (E)
6. Use floor template jig for fixing frame (J)

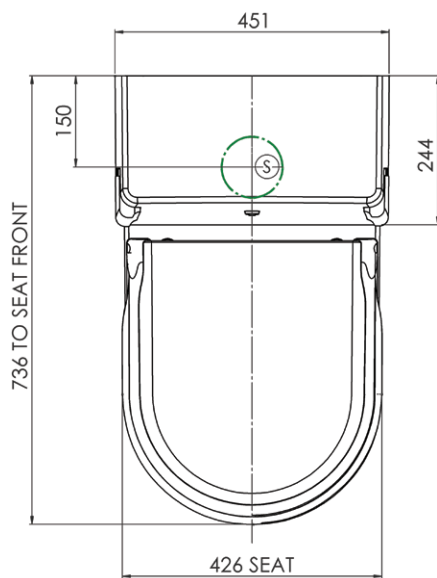
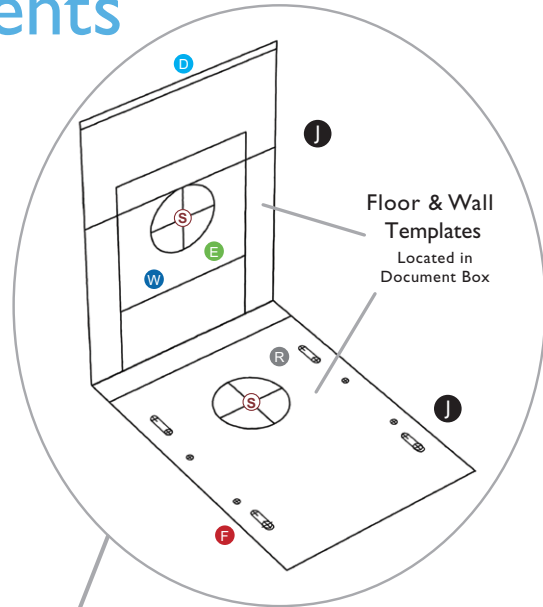

W Water services

Supplied with 15mm Stainless steel braided outer. EDM inner WRAS approved flexible hose. (Please refer to page 2, water services prior to installation)

E Electrical services

Supplied with 1000mm long, three core (live/neutral/earth) insulated 3183Y-1-white control flex-cable, rated to 220-240V, 4.5A-4.9A. (Please refer to page 2, electrical services prior to installation)

S Waste details

Pan has a horizontal spigot standard 100mm diameter outlet, suitable for standard pan connection fittings.

D Rear wall fixing

Position 25mm to RH of the centreline. 810mm from the floor.

R Rear floor fixing (2No)

(Standards Installations)
Position on the floor 102mm from the rear wall. 119.5mm to each side of the centreline.

F Front floor fixing (2No)

(When using Support Arms)
Position on the floor 327mm from the rear wall. 119.5mm to each side of the centreline.

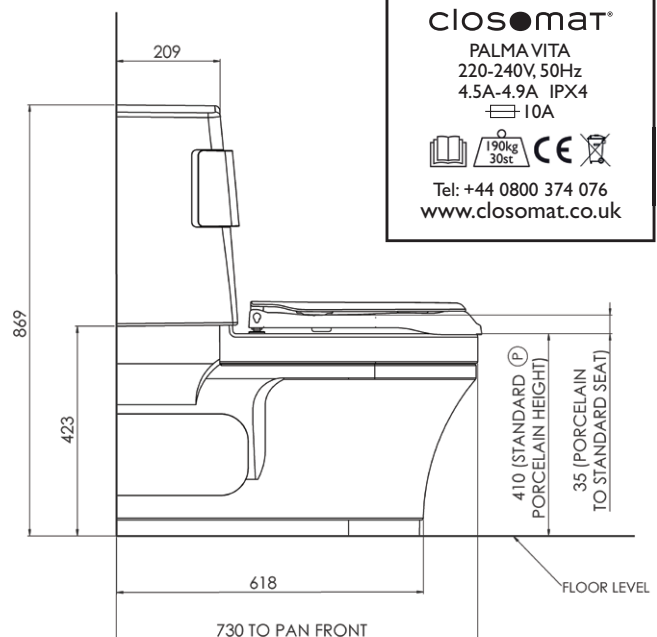
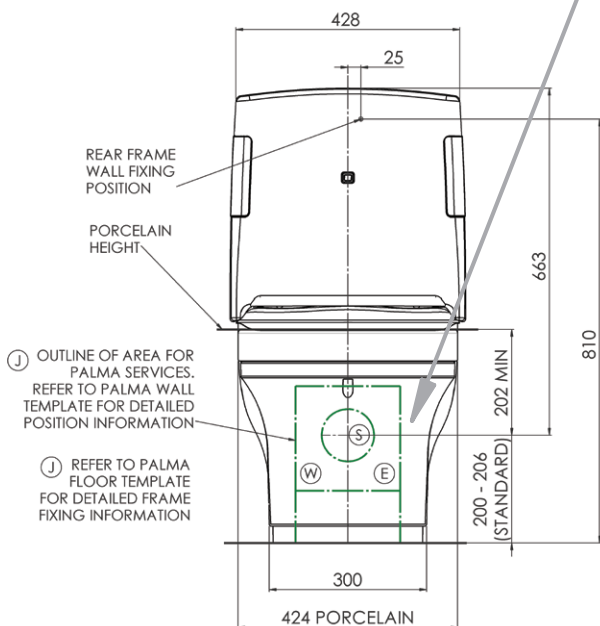

closomat®

PALMA VITA
220-240V, 50Hz
4.5A-4.9A IPX4
10A



Tel: +44 0800 374 076
www.closomat.co.uk

- Safe working load: 190kg/30st
- Overall dimensions: 869mm high x 451mm wide x 730mm deep

Installation

IMPORTANT: Please retain all packaging until the installation is complete. Protect all floor surfaces when handling the Closomat. DO NOT slide the Closomat across the flooring.

1 To lift the Closomat use the porcelain flushing edge at the front and the steel frame at rear, and lift it out of the bottom of the packing.



2 Remove the seat – Open the lid. Press and hold the seat pivots together with both thumbs whilst firmly gripping the outer edges of the seat. Now pull upwards sharply.



3 Carefully loosen and pull out the covering cap on the cistern cover.



4 Loosen the screw of the cistern cover completely, but do not remove it.



5 Gently lift the cistern cover upwards (small arrow) and then pull it forward and off (large arrow).



6 Loosen and remove the front screw.



7 Unhook the fixing adjuster brackets from the frame.



8 Repeat unhooking on opposite side ensuring cover is free.

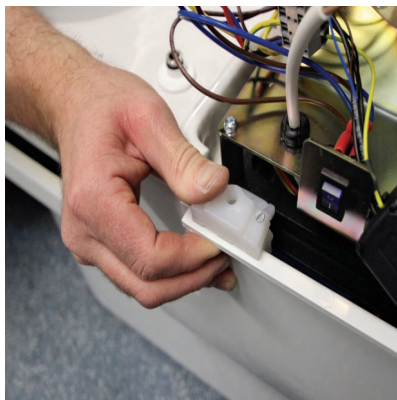

9 Pull away cover once adjuster brackets are loose.



Installation (cont.)

10 Using the template provided proceed to set the Closomat's position in the bathroom.



11 Drill four holes in the floor to best suit the intended fixings to be used for the application.



PLEASE NOTE

Two templates are provided:
One for floor installations
and
One for wall installations

12 Locate your services, with the electrical isolation positioned outside the confines of the toilet covers. Spur outlet to be located in accordance with current I.E.E. Regulations (Current Edition). If supply cord is damaged, it must be replaced by the manufacturer, its service agent or similarly qualified persons in order to avoid a hazard.



13 Cold water connection is via a 15mm connection pipe at the rear of the unit. We recommend the supply pipe enter the unit through the floor or through the wall. If side entry is necessary then a suitable infill panel will be required. The provision of an isolation valve is always recommended.



14 Position the Closomat and place all four anchor blocks in place.



15 Secure the Closomat to the floor using all four fixing points, use suitable fixing for the application. Adhesives are not allowed to be used.



16 Anchor the Closomat to the rear wall for stability.

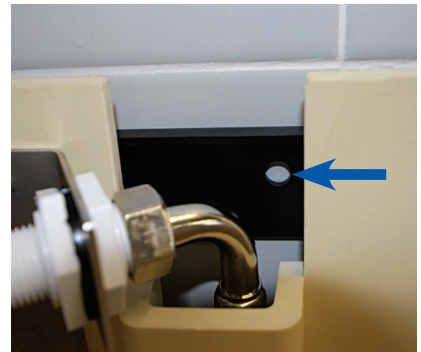

17 Remove the skirt from inside the bowl cover and insert skirt locators supplied loose.



18 Place the lower skirt around the base of the frame.



19 Ensure the skirt locator is engaged to the frame.

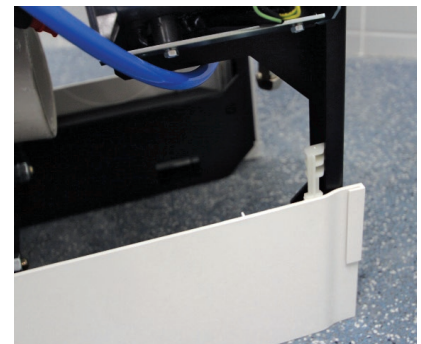

Test procedure

- 1 Fill the Closomat with water and switch on mains electricity. Locate the on/off switch and click on the on position 'I', the switch will illuminate blue. Check all joints for leaks.



- 2 Allow approximately 5 minutes for the water to heat in the boiler. Check the circuit board, the boiler light will be permanently illuminated red while the water is being heated to the operating temperature. As the water temperature approaches the required operating temperature the light will flash red. If the boiler light does not illuminate, check the safety stat has not tripped (see inset) by pressing 'click' to reset.

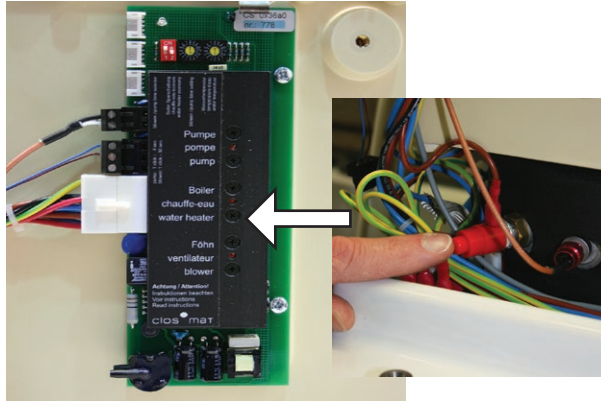

- 3 Simultaneously pressing the right hand seat hull and the operation bar will activate the warm water wash. Run the wash for approximately 30 seconds to ensure water pressure is constant.

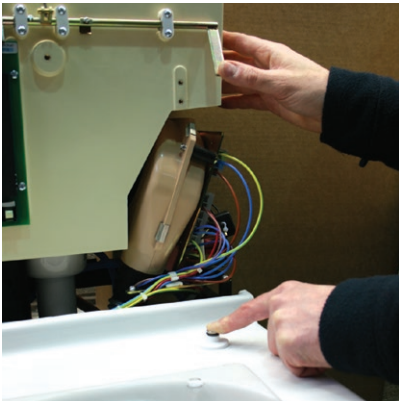

- 4 Should the wash splutter during the wash cycle described in step 4, the douche system may need purging to remove any potential air-lock, generated during the unit's transit/installation. To do this, insert the special tool supplied hook end into the recess at the bottom of the douche arm (arrow).



- 5 Pull out the douche arm using the special tool, with force against the spring pressure, until the arm reaches its maximum stop. Hold the douche arm with a free hand once fully extended, rotate the tool and locate the tool into the slot and recess in the douche arm to hold in this extended position (arrow). Run wash cycle to purge. Once wash is constant remove tool and allow the douche arm to retract.



- 6 Should the water pressure need adjusting to suit the user, locate the pump situated on the right hand side of the Closomat. Hold down or release the pump pressure spring slide by either tightening or untightening the adjacent holding nut. Clockwise will increase the pump pressure, whereas anticlockwise will achieve the opposite.



Check procedure

- 1 Ensure electrical supply is connected to unit, and switched on: check that correct fuse is fitted.
- 2 Ensure water supply is turned on and that the inlet valve is allowing water to enter the cistern and shutting off at correct level. Ensure flow of water is adequate to keep douche supplied.
- 3 Ensure rear of seat is depressed.
- 4 Keep elbow pad depressed until water runs cold. Keep seat depressed while hot air is operating.
- 5 Trouble-shooting guide available direct on our website: www.closomat.co.uk
- 6 **Ensure joints are dry and have not been disturbed during installation.**

note

- Foot switch, hand switch or remote switch, if fitted, will operate exactly as elbow pads.
- Douche temperature and pressure are preset at factory, and adjustments should only be carried out by Closomat engineers familiar with the equipment.

note

- The Closomat will not function automatically if the seat switch is not depressed.
- The unit should be switched on electrically at all times when in service.

Finishing the installation

- 1** On completion of installation and test procedure, replace bowl cover.



- 2** Hook brackets into position. Where necessary adjust to provide a water tight seal, adjust the rising block until the seals are tight against the porcelain.

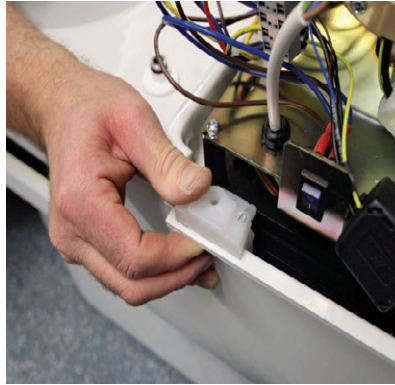

- 3** Replace and tighten the front screw.



- 4** Replace cistern cover. Ensuring the clips on the lower rear edges engage inside the bowl cover and the on/off switch is displayed in the right hand side window.



- 5** Correct fitted position of cistern cover clips – shown from rear of unit.



- 6** Replace the screw on the cistern cover and carefully tighten.



- 7** Push in the seat buffer on the cistern cover.



- 8** Replace the seat by locating the 'seat pivots' into the seat hulls fixed to the pan – press the seat firmly to secure its position.



- 9** Complete the installation by testing the Closomat works, by again depressing the seat and holding in one of the elbow pads.



Please advise us of installation address in order that we can arrange the commission and activate the 12-month guarantee.

Side entry pipes

1 With a sharp implement, remove the side panel screw covers.



2 Remove the screw and set aside.



3 Remove the side panel.



4 Install the side entry pipe scribing the side panel to suit each location, refit the side panel and screw covers on completion.



Installation on a plinth

1 Using the template provided, locate, mark and drill four holes for the plinth in the floor to best suit the intended fixings to be used for the application.



2 Secure the plinth to the floor using all four fixing points, use suitable fixing for the application, prior to installing the Closomat.



3 Locate the Closomat over the plinth.



4 Using ALL four blocks anchor the Closomat to the plinth.



Palma integrated fold-down support arms installation

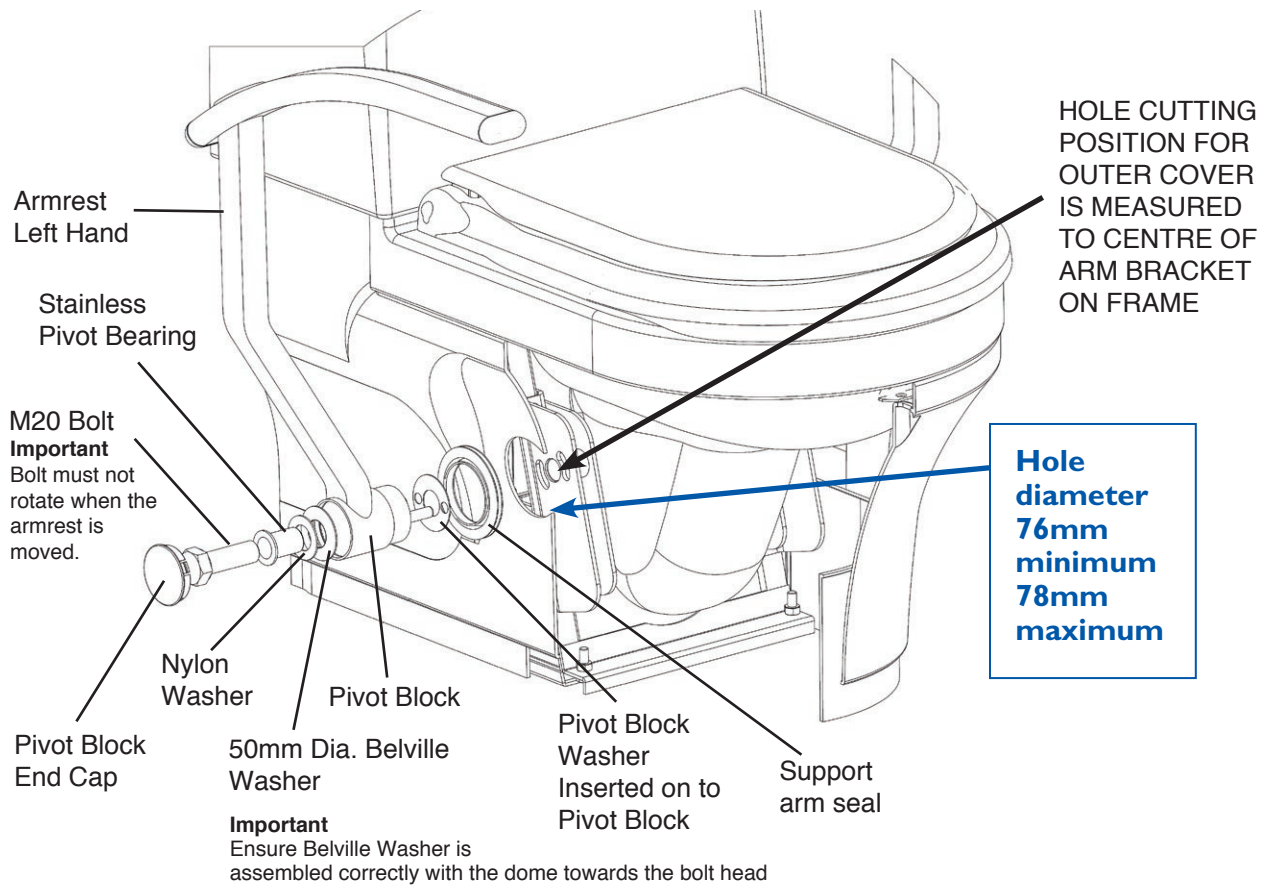

How to drill holes in the cover if armrests are fitted

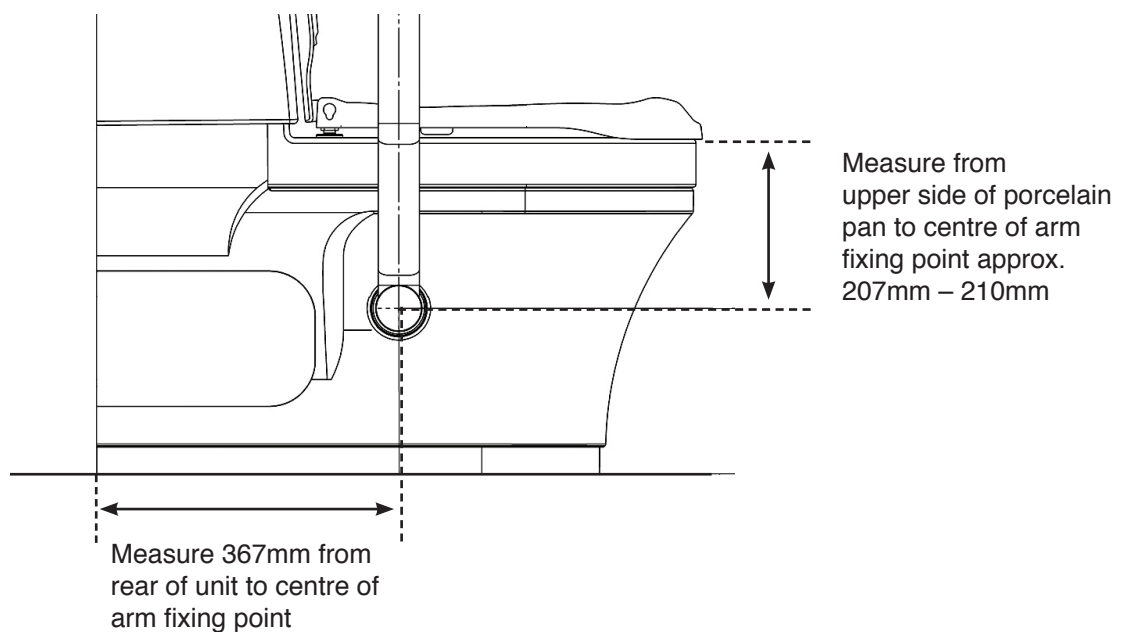

IMPORTANT NOTE:

SUPPORT ARMS MAY BE FITTED TO A CLOSMAT, FLOOR FIXING INTEGRITY IS ESSENTIAL FOR THE STABILITY OF UNITS.

Palma integrated fold-down support arms technical data

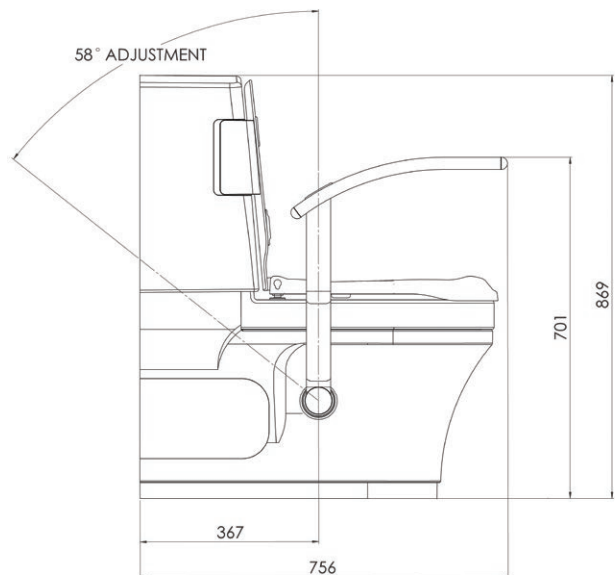
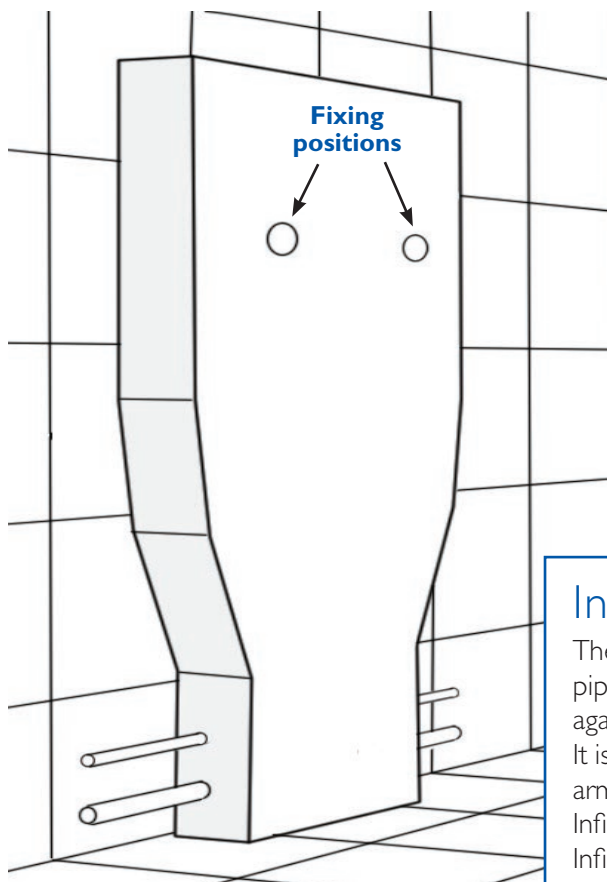
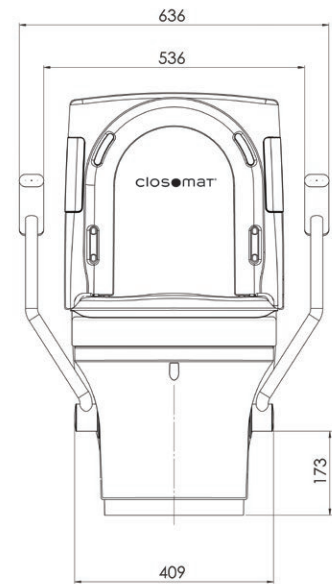
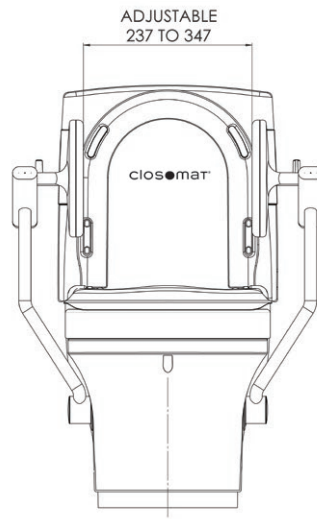
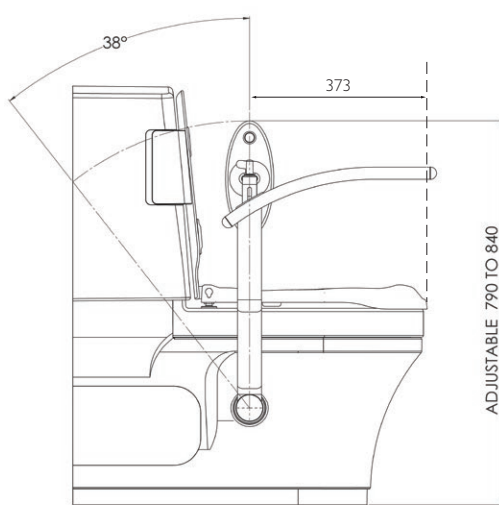

Infill panel



The infill panel has been designed to aid installation where pipe-work inhibits the Closomat toilet from being located against the wall.

It is also to be used in conjunction with an extended douche arm, where channelling the rear wall is not an option.

Infill panel available in thickness sizes 25mm, 50mm & 75mm. Infill panel is 100mm taller than Closomat toilet. It must be cut from bottom to suit finished toilet height.

www.closomat.co.uk



-  UK design and development
-  UK manufacturing
-  UK customer support

We reserve the right to make modifications as a result of ongoing adjustments and further development. This factor, and the variety of equipment options available, may result in descriptions not corresponding to the current equipment version in all details.

CLOSOMAT® has been the protected trademark of the world's first wash & dry (shower) toilet since 1957.



Closomat Ltd • Building I • Brooklands Place • Brooklands Road • Sale • Cheshire • M33 3SD



Tel: 0800 374 076 Email: info@closomat.co.uk