

User Instruction Manual

Oxford® Mermaid & Ranger

To avoid injury, read user manual prior to use. For alternative languages, contact your authorised service provider.

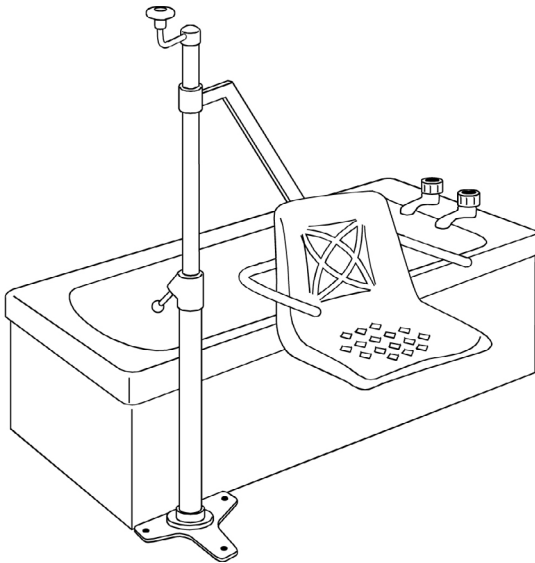

Contents

1. Statement of Intended Use	3
2. About Your Lift	4
3. Side and End Fit Illustrations	5
4. Assembly and Installation Instructions	6
5. Oxford Mermaid Electric Illustration	8
6. Fitting Dimensions	9
7. Assembly and Installation Instructions	10
8. Installation of the Base Plate	11
9. Wooden Floor Installation Kit	12
10. Testing of Installation	13
11. Operating Instructions	15
12. Safety Precautions	16
13. Taking Care of Your Mermaid	17
14. Charging Instructions (Electric Variants)	20
15. Daily Check List	22
16. Maintenance Schedule	23
17. Technical Specifications	25
18. Warranty	28

1. Statement of Intended Use

The Mermaid product is intended to be used for both single and multiple patient use.

The term **“Single Patient Use”** refers to items that are used by an individual patient only throughout the course of their program of treatment. They should only be re-used according to the recommendations outlined in the user manual and must be kept in a clean condition, stored appropriately and only re-used by the same patient.

The term **“Multiple Patient Use”** refers to items that are used by multiple patients throughout the course of their program of treatment. They should only be re-used with a different patient after being cleaned according to the recommendations outlined in the user manual and must be kept in a clean condition and stored appropriately.

In all cases it is required that a clinical risk assessment has been carried out to verify that the patient has sufficient upper body strength to enable him/her to maintain a steady position whilst in the chair. Also verifying that the patient has sufficient mental capacity to adhere to the caregivers instructions.

The assessment should be carried out by a qualified nurse or therapist before lifting patients with the Mermaid hoist.

A lap strap is fitted to the seat of the Mermaid Hoist to enable it to be used when required by the clinical risk assessment.

PLEASE NOTE:

1. If there is a risk of cross infection when using a lap strap on a Mermaid hoist, the hoist should only be used for Single Patient Use.
2. If a Mermaid hoist and lap strap is used for Multiple Patient Use, and a risk of cross infection has been identified, a different lap strap should be used for each patient.

For details on how to remove or replace the lap strap, please refer to the fitting instructions supplied with each lap strap.

WARNING

Oxford patient lifts should only be operated by fully trained/competent care givers.

Minimum Expected Life

Oxford Mermaid and Ranger products are designed and tested for a minimum service life of seven (7) years, subject to the use and maintenance procedures in this manual. Use other than in accordance with these instructions may compromise service life.

Serious Incident Reporting

In the event of a serious incident taking place during use of this product, affecting the patient and/or care-giver, it must be reported to the product manufacturer or authorised distributor. Should the incident take place within the European Union (EU), it must also be reported to the local competent authority within the member state.

2. About Your Lift

Each lift is fully assembled, load tested and certified before being partially dismantled for packing.

The installation of the lift cannot be factory tested so it is important to carry out the installation according to the guidelines provided in this manual. The packing consists of a strong, purpose built carton and is used for both export and domestic markets to ensure the safe arrival of the lift. A number of documents are supplied in a wallet packed with each lift and should be kept safely for future reference:

- Test Certificate
- User Manual

The TEST CERTIFICATE is an important document and will be required for your insurance records. It is valid for six months and after it has expired the lift should be inspected and serviced for the following six month period. Servicing and periodic testing can be carried out by your supplier. Please ensure your lift is included in their maintenance schedule.

The Oxford Mermaid & Oxford Ranger are suitable for Category C - Bath within the working parameters of the lifts specified in the TECHNICAL SPECIFICATIONS.

The Oxford Mermaid & Oxford Ranger are suitable for patients in the SITTING position.

The CE mark:

The Oxford Mermaid & Oxford Ranger carry the CE mark and comply with the following EC directives:



- Medical Device Directive (93/42/EEC)
- Low Voltage Directive (2006/95/EC)

3. Side and End Fit Illustrations

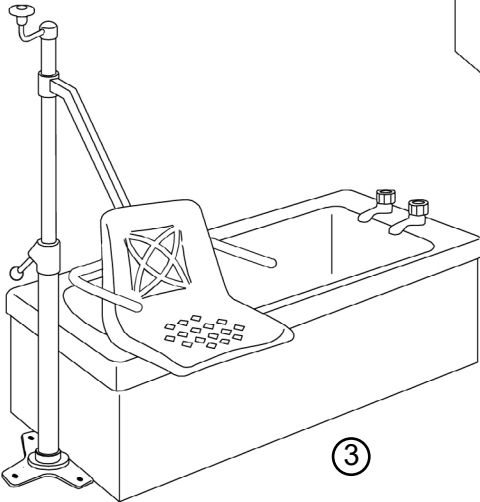
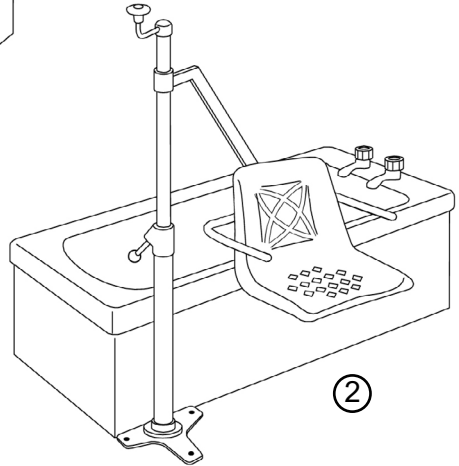
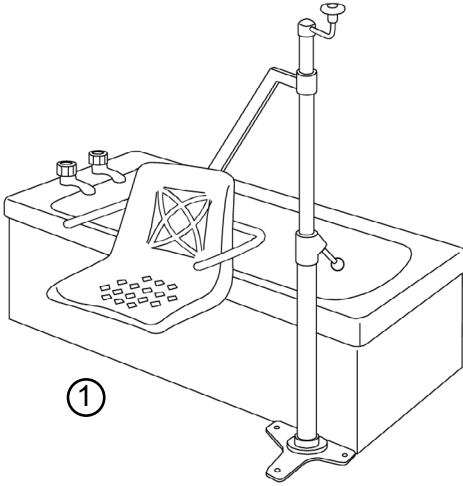

1. Left hand side fit
2. Right hand side fit
3. End fit

4. Assembly and Installation Instructions

- Models:**
- Oxford Mermaid
 - Oxford Ranger
 - Oxford Electric Mermaid
 - Oxford Electric Ranger

Oxford bath lifts are supplied with a universal base plate. Concrete floors and wooden floors require different fixing kits. The lifts are packed with fixing kits to suit both wooden and concrete floors.

Mermaid and Ranger lifts can be fitted in two positions relative to the bath. The most common is the side fit, where the mast is fitted at the side of the bath, and the end fit, where the mast is fitted on the centre line of the bath at one end (see illustration on page 5). The end fit option requires a different arm arrangement and must be specified at the time of ordering.

PACKING: The Mermaid and the Ranger lifts are supplied in two cartons.

Oxford Mermaid 1st carton:

- MAIN MAST ASSEMBLY (15kgs)
- UNIVERSAL BASE PLATE (5kgs)
- CONCRETE / WOOD FLOOR FIXING KIT
- SEAT SUPPORT ARM (2.3kgs)
- FOLD UP SAFETY ARMS (2) (2kgs)
- WALLET CONTAINING DOCUMENTS

Oxford Mermaid 2nd carton:

- SEAT ASSEMBLY (4.5kgs)
- LAP STRAP (0.2kgs)

Oxford Ranger 1st carton:

- MAIN MAST ASSEMBLY (15kgs)
- UNIVERSAL BASE PLATE (5kgs)
- CONCRETE / WOOD FLOOR FIXING KIT
- SEAT SUPPORT ARM (3kgs)
- WALLET CONTAINING DOCUMENTS
- LAP STRAP (0.2kgs)

Oxford Ranger 2nd carton:

- RANGER SEAT ASSEMBLY (6kgs)
- SAFETY ARMS (2) (2kgs)
- TRANSPORTER CHASSIS (9.4kgs)
- LAP STRAP (0.2kgs)

Oxford Mermaid Electric 1st carton:

- MAIN MAST ASSEMBLY (15kgs)
- UNIVERSAL BASE PLATE (5kgs)
- HAND CONTROL
- POWER PACK
- CHARGER
- CONCRETE / WOOD FLOOR FIXING KIT
- SEAT SUPPORT ARM (2.3kgs)
- FOLD UP SAFETY ARMS (2) (2kgs)
- WALLET CONTAINING DOCUMENTS

Oxford Mermaid Electric 2nd carton:

- SEAT ASSEMBLY (4.5kgs)

Oxford Ranger Electric 1st carton:

- MAIN MAST ASSEMBLY (15kgs)
- UNIVERSAL BASE PLATE (5kgs)
- HAND CONTROL
- POWER PACK
- CHARGER
- CONCRETE / WOOD FLOOR FIXING KIT
- SEAT SUPPORT ARM (3kgs)
- WALLET CONTAINING DOCUMENTS

Oxford Ranger Electric 2nd carton:

- RANGER SEAT ASSEMBLY (6kgs)
- SAFETY ARMS (2) (2kgs)
- TRANSPORTER CHASSIS (9.4kgs)

Check the contents of the cartons carefully. If any parts are missing or damaged, contact your supplier immediately.

5. Oxford Mermaid Electric Illustration

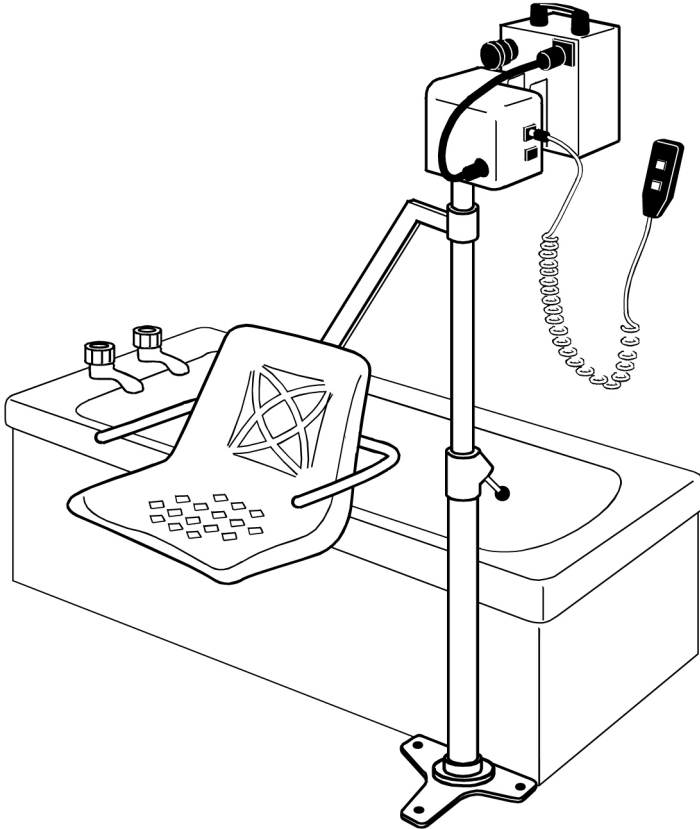

6. Fitting Dimensions

End Fitting:

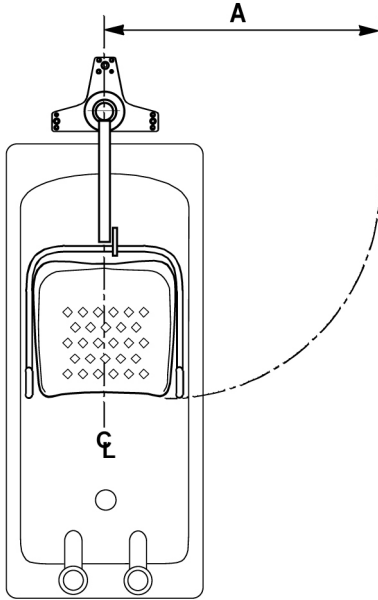

Side Fitting:

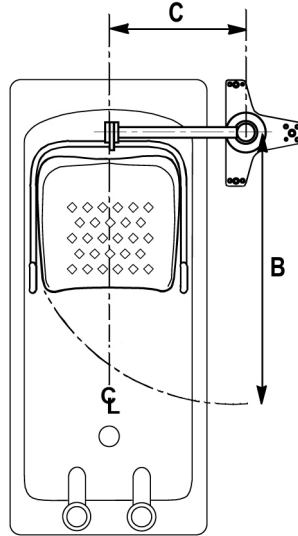

	Mermaid	Commode	Ranger
A =	865mm	815mm	890mm

	Mermaid	Commode	Ranger
B =	850mm	810mm	810mm
C =	430mm	430mm	430mm

Universal Base Plate Principle Dimensions:

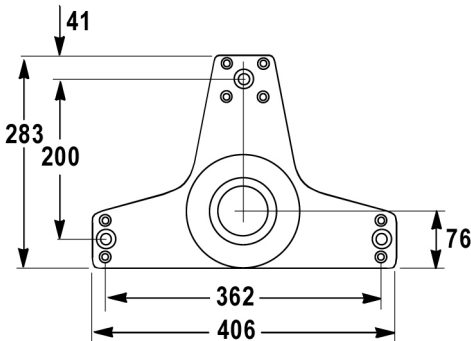

7. Assembly and Installation Instructions

WARNING

It is recommended before commencing installation that an architect/structural engineer is consulted to verify the structural integrity and suitability of the floor.

CAUTION

It is recommended the installation is performed by a Joerns Healthcare approved dealer or competent person.

1. Remove all the parts from the carton and place on the floor, taking care to protect the finish from damage.

SAFETY NOTE: Some of the parts are heavy and will need to be lifted with care. You may need assistance with the heavier assemblies.

2. Before commencing assembly establish the seat position required. The drawing on page 5 will help clarify whether a left, right or end fit arm is required.
3. Having established the position of the seat, assemble the Mermaid seat and safety arms to the chair support arm. These components are fixed together with two stainless steel nuts and bolts.

Mast Positioning:

Baths vary greatly in shape and size. It is very important to establish the exact position of the mast in relation to the particular bath.

IMPORTANT NOTE: The lift seat may damage the sides or back of the bath if it is incorrectly fitted.

1. Place the base plate on the floor in the approximate final position. Locate the mast onto the four base plate fixing studs. Lightly tighten down the nuts onto the studs.
2. Connect the seat and arm to the Mermaid column. Secure the seat arm with the safety screw. The whole unit will require supporting during this operation.
3. Position the seat in the bath cavity and move the whole assembly until the seat is in the optimum position. This is with the seat on the centre line of the bath with clearance both sides and as far back as the design of the bath will allow. Make sure there is clearance under the seat and make allowance for some downward movement when the seat is loaded. This will avoid damage to the surface of the bath.
4. With the lift in the optimum location, mark the position of the base plate fixing holes. Check the area for hidden services. Remove the base plate from the column, this will make it easier to handle while fixing.

8. Installation of the Base Plate

Concrete Floors:

Establish with your architect the structural integrity of the concrete floor, bearing in mind the stresses imposed by the Mermaid. In brief, a sound floor of at least 120 - 150mm thickness of good concrete is ideal. An element of screed is acceptable, as long as the expanding section of the fixing bolts are in sound concrete.

Drill three 16mm diameter x 125mm deep holes in the positions marked out from the base plate. Locate the base plate over the holes and insert the expanding bolts.

NOTE: The expanding bolts which are supplied with the lift are designed to be fitted fully assembled, **DO NOT** take them apart. Tighten the bolts fully with the Allen key supplied.

IMPORTANT NOTE: Not all concrete floors are constructed in a manner which allows for this type of fixing. Floors which are constructed from precast beams with block infill do present a problem which cannot be overcome easily. If your floor is of this construction, or you suspect it may be, consult an architect/structural engineer for guidance.

Wooden Floors:

Establish with your architect the structural integrity of the wooden floor, bearing in mind the loading and stresses imposed by the lift. There are many forms of wooden floor construction. The following information should be regarded only as guidelines for your installer, whose knowledge and skill will be an important factor in the secure and safe installation of the lift. Not all wooden floors are constructed in such a way to allow for lift mounting without extensive strengthening. If in any doubt consult an architect/structural engineer.

For the most common floorboard construction, an underfloor bracing kit is supplied as a standard pack. It may not suit all applications. See the illustration on the following page.

If the location of one or more of the base plate fixing holes coincide with a joist, then a heavy wood screw or coach bolt can be used in conjunction with the bracing kit.

Additional holes in the base plate allow for extra location points on wood floors.

Floorboards in the immediate area of the base plate should be secured to the joists with heavy wood screws.

It is important that fixing should be carried out on sound and suitable floors only.

Chipboard and similar lightweight floors will need to be reinforced locally. The advice of an architect/structural engineer should be sought to establish the amount of reinforcing necessary.

Joists can be reinforced by fixing strengthening sections alongside and between existing joists.

Floors can be strengthened by additional local fixing to the existing joists and/or by using a heavy marine plywood inset.

If in doubt, seek professional advice.

9. Wooden Floor Installation Kit

Two steel bars are provided for the safe installation of the bath lift to wooden floors. The bars should be used as follows:

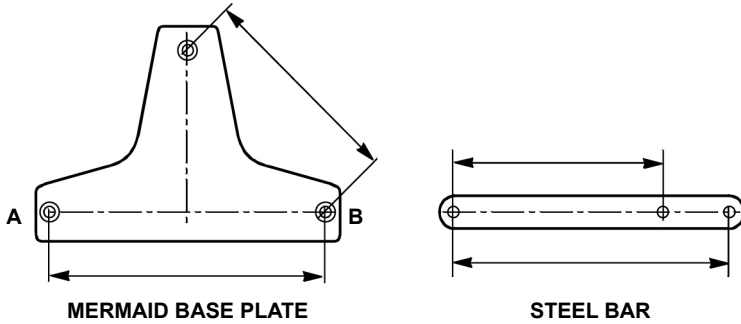

All three holes in the base plate should be used, with one bar spanning either 'A' or 'B' and the other bar bolted through the third hole. Three countersunk steel screws are supplied for this purpose. Ideally each bar should span as many floorboards as possible (usually three). Whether a bar will span either 'A' or 'B' will be decided according to the direction and position of the joists in the area chosen for sitting the Bath Lift.

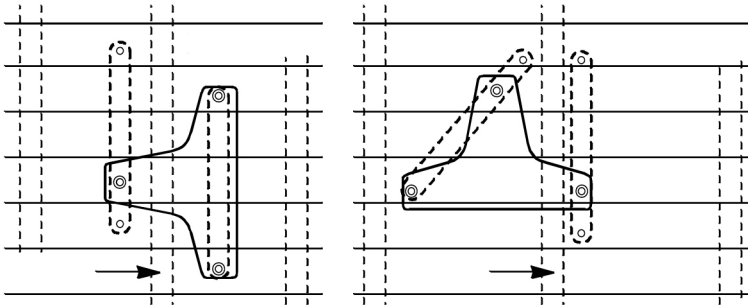

Access is normally achieved by removing a section of floorboard adjacent to the fixing area large enough to allow the insertion and positioning of the bars. All floorboards taking any part of the load should be securely fastened down to the joists with 4" (100mm) countersunk wood screws. The final installation should be tested according to the manufacturers recommendations.

10. Testing of Installation

With the base plate firmly installed, place the mast back onto the base plate studs and fully tighten down the four nuts.

IMPORTANT: It is strongly recommended the installation of the base plate is load tested before the Mermaid is put into use.

Following the recommendation in BS 10535, the installed lift should be load tested to 125% of the safe working load. In the case of the Mermaid and Ranger the test load is 157 kgs. This load is applied to the centre of the seat.

DO NOT ignore this test. If in doubt contact your supplier.

IMPORTANT NOTE:

Please take into consideration the turning radius required for clearance of the patients knees from radiators, walls or other obstructions. A minimum radius of 1 metre from the centre of the mast is recommended.

Setting Up:

The Mermaid and Ranger models have a setting up procedure which must be followed to ensure the lift operates safely and causes no damage to the bath or fittings.

Seat Locking System:

The seat locking system engages at four, 90 degree positions and is operated by a locking lever situated on the main mast. With the lever fully UP, the seat is unlocked and free to rotate 360 degrees. When the locking lever is fully DOWN, the seat will lock in one of the four positions. If the lever is pushed down at an intermediate position it will automatically engage when it encounters the next locking position.

DO NOT use this automatic engagement to stop the swing of a loaded seat. If the latch is used repeatedly to stop a moving loaded seat, the latch will be damaged and replacement required.

Setting the Four Positions Relative to the Bath:

Check the position of the seat in relation to the bath. If the seat is not central in the bath cavity it's position can be adjusted as follows.

Slacken the seat support clamp by loosening the Allen headed screw on the side of the clamp. This will allow the clamp, seat and seat arm to rotate. Engage the seat locking and swing the seat until it is in line with the centre line of the bath. Lightly tighten the Allen headed screw. Release the seat lock and rotate the seat through 90 degrees. This will place the seat in the normal position at the side of the bath. If this is the only adjustment required FULLY tighten the Allen headed screw. If height adjustment is required, leave the Allen screw lightly tightened and go on to next section.

Height Adjustment of the Seat:

The seat height must be carefully set to avoid damage to the bottom of the bath in normal use. With the seat aligned with the centre line of the bath, slacken the seat clamp again.

Take care not to allow the seat to rotate out of alignment, slide the clamp up to its maximum position and lightly re-tighten. Using the hand control, wind the seat to its lowest position (until the bottom stop is encountered). Slacken the clamp again and carefully slide it down the mast until the bottom of the seat is 3 - 5cms from the bottom of the bath. Lightly tighten the clamp and recheck the alignment of the seat in the bath. FULLY tighten the clamp Allen screw. The Allen screw is high tensile and must be fully tightened to effect a positive lock.

If the seat hits the bath before the end stop is encountered, additional steps must be taken to avoid damage to the bath. The Mermaid and Ranger have been designed to be compatible with a wide range of bath designs but the installer may encounter baths which do not conform to "normal" design. If the seat "bottoms out" before the end stop on the lift is encountered, this indicates the bath is elevated higher than normal. Firstly, check the seat is wound up to the highest position and clears the top edge of the bath.

Remember, a loaded lift will be lower than an unloaded one, so make sure there is sufficient clearance. If the seat satisfactorily clears the top edge of the bath then a stop collar (available optionally) can be used to set the lowest position. If the seat does not clear the top edge of the bath then the lift must be fitted with spacers (available optionally) at the bottom of the mast. The spacers are 75mm in height and a maximum of 2 can be used, giving a maximum additional height of 150mm.

Contact Joerns Healthcare Ltd for the supply of either of these items.

11. Operating Instructions

WARNING

Oxford patient lifts should only be operated by fully trained/competent care givers.

Mermaid Model:

The Mermaid range of bath lifts are designed to be simple and safe to use. Carefully follow these simple instructions to ensure trouble free operation.

Raising and Lowering:

The patient seat is raised or lowered on the manual versions of the bath lifts by use of the winding handle on the top of the lifting column, anticlockwise for lift and clockwise for lower. The limit of travel is governed by positive stops built into the mechanism.

It will be very obvious to anyone operating the lift when these stops are encountered.

NOTE: Do not attempt to force the winding handle past the stops as this will damage the mechanism and will lead to expensive repairs.

Electric Mermaid:

The patient seat is raised or lowered on the electric versions of the bath lifts by the hand control which is plugged into the control unit at the top of the main column. Pressing the buttons marked with directional arrows will RAISE or LOWER the seat. The limit of travel is governed by positive electronic stops built into the circuitry.

NOTE: Repeated activation of the hand control buttons once the end stops are encountered will damage the control circuitry and shorten working life.

Rotating the Seat Support Arm:

To rotate the seat support arm, fully lift the locking lever. With the lever fully UP, the seat support arm is unlocked and free to rotate 360 degrees. When the locking lever is fully DOWN, the seat support arm will lock in one of four positions. If the lever is pushed down at an intermediate position it will automatically engage when it encounters the next locking position. Do not rely on the positional lock to halt the patient's swing as this can cause high loading on the latch and may eventually lead to failure.

Ranger Model:

The Ranger differs from the Mermaid and requires some additional instructions.

The Ranger chair is made in two assemblies, a wheeled base and a seat with armrests. The two assemblies of the complete chair are connected with a simple latch located at the rear of the seat. The chair is attached to the bath lift as follows:

1. The chair support arm of the lift has a hook and latch device similar to the one connecting the seat to the wheeled base. The support arm hook must be engaged with the cross bar at the top of the seat. The latch will engage automatically and prevent accidental disengagement.
2. The seat can now be lifted off the wheeled base by operating the seat latch, which holds the seat to the wheeled base, and raising the support arm of the lift with the hand control or winding handle. The seat will be elevated with the support arm and the wheeled base will remain behind.

3. To reconnect the seat to the base, lower the seat with the hand control or winding handle back onto the wheeled base with the lower safety latch in approximately the right position. The seat will lock automatically as it is lowered. When the seat latch on the base is engaged, disengage the latch on the chair support arm and continue to lower. The support arm will drop away from the seat and can be swung away to one side. Check full engagement of the seat latch. The patient can now be transported to another location.

IMPORTANT NOTE: When the seat is fully secured to the transporter, it is important to ensure the upper safety latch is completely disengaged. Damage to the rear castors will occur if the bath lift continues to be lowered with this latch engaged or partially engaged.

The safety locking system has been designed to be very visible and very obvious in operation - double check the latches have engaged or disengaged correctly.

NOTE: Joerns Healthcare Ltd recommend a few “dry runs” without the patient in place, to familiarise users with the operation of the transporter chair and bath lift.

Emergency Raise: (Electric Variants Only)

This facility will raise the seat should the lift fail to rise with the hand control. It is for emergency use only and should not be used for routine raising. The switch is located on the power unit cover.

12. Safety Precautions

Please read and follow the safety precautions listed below. The operation and use of the Oxford patient lifts is simple and straightforward. Following these few basic safety precautions will make lifting operations easy and trouble free.

READ AND UNDERSTAND THE USER INSTRUCTION MANUAL BEFORE USING YOUR “MERMAID & RANGER” PRODUCTS

WARNING: Important safety information for hazards that might cause serious injury.

CAUTION: Information for preventing damage to the product.

NOTE: Information to which you should pay special attention.

WARNING

- **Oxford patient lifts should only be operated by fully trained/competent care givers.**
- It is required to conduct a thorough risk assessment to determine the suitability of this product for each patient prior to use. Failure to do this may result in injury to the patient and/or care-giver.
- **ALWAYS** plan your lifting operation before commencing.
- **ALWAYS** carry out the DAILY CHECK LIST before using the lift.
- **ALWAYS** familiarise yourself with the operating controls and safety features of a lift before lifting a patient.
- **ALWAYS** check the safe working load of the lift is suitable for the weight of the patient.
- **ALWAYS** carry out lifting operations according to the instructions in the user manual.
- **NEVER** disconnect or bypass a control or safety feature because it seems easier to operate the lift.
- **NEVER** force an operating or safety control. All controls are easy to use and do not require excessive force to operate. If a control is not working easily there will be a reason. Forcing will only strain or damage the lift and may compromise safety.
- **DO NOT** charge an electric hoist in a bathroom or shower room.
- **DO NOT** lift a patient unless you are trained and competent to do so.
- YOUR lift is for patient lifting. **DO NOT** use it, or allow it to be used, for any other purpose.

13. Taking Care of Your Mermaid

Oxford recommends that your Mermaid bath hoist and associated accessories are cleaned thoroughly and regularly.

When the hoist and/or accessories require cleaning, or if there is a suspicion of contamination, please follow the cleaning and/or disinfection procedures outlined below.

Any cleaning should be carried out prior to re-using the product. This is especially important when using the same hoist and/or accessories with more than one patient, as there may be a risk of cross infection.

When cleaning and disinfecting the Mermaid hoist, it is recommended that you wipe down all surfaces with a damp cloth using warm water and disinfectant. A GPD (general purpose detergent or detergent wipe) should be used.

WARNING

Do not use harsh chemical cleaners or abrasives as these may damage the surface finish of the lift. Avoid wetting any of the electrical parts.

Always read the instructions on the disinfectant/cleaner container before use.

Always wear protective gloves, clothing and eye protection when using disinfectant.

Do not over wet areas of the product which could cause problems with internal corrosion.

Do not use petroleum based solvents or similar, since this may cause damage to the plastic parts.

For disinfection of contaminated hoists, it is recommended that you wipe down the product completely with hard surface disinfectant wipes impregnated with a 70% v/v solution of Isopropyl Alcohol.

Always follow health and safety guidelines when using and handling any cleaning materials and disinfectants. These are normally detailed on the container.

Cleaning of the Mermaid Standard, Ranger and Commode Seats:

By following the instructions detailed above, it will provide an effective method of cleaning and/or disinfecting for the exposed surface areas on the hoist. For internal surfaces and hard-to-clean crevice sections, Oxford recommends that the seat and frame is immersed in a disinfectant/cleaning solution and cleaned in the following manner:

Mix a suitable quantity of solution in the bath tub, following the instructions on the disinfectant/cleaner container.

If a lap strap is fitted, this can be removed and cleaned separately to aid cleaning of the seat frame. Refer to the lap strap fitting and removal instructions. Cleaning instructions for the lap strap are detailed later in this section.

NOTE: A mild scrubbing action is required as well as the disinfectant/cleaner to sanitise any surface.

Lower the seat frame into the bath and then clean both the seat and frame. When cleaning the Ranger and Commode seat, it is necessary to lift the seat section, as shown in Photo CL1. Do not clip the seat back into position until the seat frame is removed from the bath and the cleaning process has been completed.

The inside of the support tubes (See photo CL2) can be cleaned using an appropriate long handled, stiff bristled 'bottle type' brush.



Photo CL1

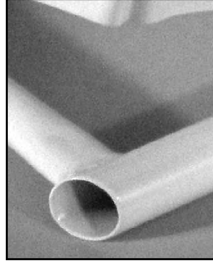

Photo CL2

Pay particular attention to any recesses in the framework and seat.

Raise the seat frame clear of the disinfectant solution and clean thoroughly underneath.

⚠ WARNING

Care is needed when draining out disinfectant solution from the support tubes as the seat frame is being raised.

After cleaning, the disinfectant solution can be drained from the bath and the hoist should then be rinsed with clean water. Finally, thoroughly dry the product with a disposable cloth.

For the Ranger and Commode seat, make sure that the seat is correctly clipped back into position and securely fitted to the frame.

⚠ WARNING

Thoroughly clean the brush in a fresh solution of disinfectant/cleaner. Rinse well with clean water. Dry the brush and store ready for the next cleaning operation.

PLEASE NOTE: As methods and good practises evolve over time, the instructions detailed above may differ from your own recommended guidelines. If in doubt, please contact your local authorised Oxford dealer or Joerns Healthcare directly.

Cleaning the Lap Strap:

The lap strap can be easily cleaned, rinsed and re-applied to the seat.

Follow all precautions and warnings highlighted in the earlier sections of this manual.

The lap strap material can be cleaned using hard surface disinfectant wipes that are supplied impregnated with a 70% v/v solution of Isopropyl Alcohol. Thoroughly wipe clean the lap strap.

The buckle can be cleaned either using a disinfectant spray or by immersing it in a suitable quantity of disinfectant solution, in a suitable container. The buckle can then be rinsed with clean water.

Dry both the buckle and strap with a disposable cloth.

Refit the lap strap to the product, referring to the fitting instructions.

14. Charging Instructions (Electric Variants)

The batteries are located in the power pack and are charged through a socket which also serves as the power supply socket for the lift. The socket is labelled POWER/CHARGING POINT. The battery pack on the Oxford Mermaid can be removed from the lift and charged independently. An additional battery pack can be supplied, if required, so that one pack can be on charge at all times.

1. Remove the power supply plug from the POWER/CHARGING POINT socket. The plug is removed with a straight pull. **DO NOT** twist the plug in the socket. The battery pack can now be removed from the lift for charging elsewhere. To remove the battery pack simply pull the battery pack up by the handle on top of the pack and disengage the pack from the locating pins on the mast. Reverse the process for reconnection.
2. Connect the battery charger plug to the POWER/CHARGING POINT socket. The plug is indexed and can be fitted only one way. Make sure the red locking ring on the charging plug is in the unlocked position (Moulded pointer on the locking ring pointing to the "Unlocked position"). Connection is achieved with a straight push and then the locking ring can be twisted to "Lock" position.
3. Plug the charger mains plug into a suitable mains outlet and switch the mains supply ON.
4. Charging is fully automatic. The status of the charging is indicated by two LED indicators (see table below). **Note:** Even if the charger is left plugged in for extended periods it will not allow the batteries to "overcharge".
5. To return the lift to service, switch OFF the mains supply, twist the locking ring on the charger plug to "Unlocked" and disengage from the POWER/CHARGING POINT with a straight pull. **DO NOT** pull on the cable to disengage the plug. The power supply plug can be reconnected with a straight push. **DO NOT** twist the plug in the socket. The lift is now ready for use.

Charger Status	LED Indicators
Bulk charger mode	Yellow - static ON
Battery charged	Green - static ON
Battery reversal detected	Yellow - flashing
High temperature detected	Yellow + Green flashing simultaneously
Short circuit	Yellow + Green flashing alternately
Open circuit	Yellow + Green static simultaneously

The charging of Oxford electric lift is simple and straightforward, but it is important to follow the charging instructions closely. Please pay particular attention to the following points, it will help you avoid problems with discharged batteries.

- **KEEP** the batteries fully charged. Place the battery on charge whenever it is not in use. The charger will not allow the batteries to “overcharge”.
- **NEVER** run the batteries completely flat. If the audible warning sounds, complete the lifting operation in hand and place the battery on charge.
- **NEVER** store the lift for long periods without regular charging throughout the storage period.
- **ALWAYS** make sure the mains power to the charger is switched off before connecting or disconnecting the charger to or from the battery.
- **NEVER** leave the charger plugged in to the battery with the mains power off.
- **NEVER** disconnect the charger plug by pulling on the cable.

15. Daily Check List

Oxford Bath Lifts are designed to comply with **BS EN ISO 10535: 2006: Hoists for the transfer of disabled persons - Requirements and test methods** which recommends a bi-annual thorough examination and an annual service and test, but, in order to comply to the statutory provisions of **1998 No 2307 Health and Safety: The Lifting Operations and Lifting Equipment Regulations 1998** Joerns Healthcare Ltd recommend a six monthly inspection and test.

Statutory requirements for regular servicing may alter from region to region, please check your regional regulations.

Daily checks and a regular service, inspection and test will ensure a lift is kept in optimum safe working condition. A list of spare parts is available upon request. The LOAD TEST and certification should be carried out by qualified personnel or an authorised Service Dealer.

Daily Check List:

WARNING

Joerns Healthcare strongly recommends the following checks are carried out on a daily basis and before using the lift. Failure to carry out these checks may result in injury to the patient and/or care-giver.

- **MAKE** sure the hand control (electrics only) is plugged in firmly and the lift raises and lowers smoothly.
- **MAKE** sure the winding handle on manual lifts operates smoothly and the lift raises and lowers.
- **CONFIRM** the Mermaid is not sounding a low battery alarm (electrics only) when the hand control is operated. If the alarm sounds, **DO NOT** use and place the power pack on charge immediately.
- **CHECK** the operation of the emergency stop button (electrics only).
- **CHECK** the operation of the emergency raise button (electrics only).
- **MAKE** sure the castors on the Ranger chair are free to rotate and the brakes operate.
- **CHECK** that the seat is securely fitted to the frame.
- **CHECK** that the seat support arm is free to rotate.
- **CHECK** the support arm safety screw is in place and fully tightened.
- **CHECK** that the lap strap is securely fitted to the seat frame and functions as intended.
- **CHECK** that the lap strap is not damaged (i.e. not frayed).
- **CHECK** that the lap strap buckle locks securely and is not damaged.

16. Maintenance Schedule

Joerns Healthcare Ltd recommend the following tasks are carried out by authorised service dealers only.

FLOOR FIXING: Check the base plate fixing is sound and secure. Follow the test routine as detailed in the installation instructions. Wooden floors require inspection at more frequent intervals.

MAST TO BASE: Check the four Nyloc nuts securing the mast to the base plate are fully tightened. Check also for signs of grease leakage between the mast and the base plate.

CHAIR SUPPORT CLAMP: Check the chair support clamp is correctly orientated as per the Setting Up instructions. Make sure the seat does not touch the side or bottom of the bath. Check the seat locks in the correct positions. CHECK the operation of the seat lock.

SUPPORT ARM: Check the support arm has the safety screw in position and tightened. Check the seat is securely attached to the support arm and the fixing nuts and bolts are fully tightened.

SEAT: Check the seat for splits or damage. Check the Mermaid seat for presence of nine safety plugs fitted to the seat moulding (Lifts before December 1998). Check that the seat is securely fitted to the frame.

RANGER BASE CASTORS: Check all castors are free running. Check for secure fixing to the base legs. Check brakes for correct operation.

SAFETY LATCHES: Check the correct function of the safety latches on the Ranger Chair and the Ranger support arm.

LAP STRAP FITTING: Check that the lap strap is fitted securely to the seat frame and is not frayed, worn or damaged.

SEAT FIXING: Check that the seat is securely fitted to the frame.

HOIST CLEANING: Refer to section 13.

LAP STRAP CLEANING: Refer to section 13.

LOAD TEST: The load test should be carried out in accordance with the manufacturer's test procedures and the directive detailed in EN ISO 10535:2006 - Annex B - Periodic Inspection B1 - see excerpt below. It is strongly recommended that an authorised service dealer carry out the test.

EN ISO 10535:2006

Annex B

(Informative)

Periodic Inspection

B. 1 Periodic inspection of the hoist should be undertaken at the time intervals stated by the manufacturer, but at least once a year. By periodic inspection is meant a visual examination (particularly of the hoist's load bearing structure and lifting mechanism with attachments, brakes, controls, safety devices and person-support devices) and whatever function tests and maintenance measures may be required, e.g. adjustment of brakes, tightening of fasteners.

Every inspection should include a working load test of one (1) lifting cycle with the maximum load.

CERTIFICATION: An authorised service dealer will issue a test certificate after satisfactory completion of the load test. This certificate will be valid for the period stated on the certificate.

Additional Tasks for Electric Variants Only:

HAND CONTROL: Check the correct operation of the RAISE and LOWER buttons on the hand control. Take the seat to the lowest position and confirm the operation of the bottom stop. Check the seat does not hit the bottom of the bath. Prevent the downward movement of the seat and check the power is switched off automatically.

MOTOR UNIT: The motor should require no maintenance other than checking for correct operation and listening for unusual noise.

BATTERIES: The batteries are housed in the power pack and should not require maintenance other than regular charging as detailed in the charging instructions.

EMERGENCY STOP BUTTON: Check the operation and correct functioning of the emergency stop switch located on the rear of the power pack.

EMERGENCY RAISE SWITCH: Check the operation and correct functioning of the rocker switch located on the motor unit.

END OF LIFE DISPOSAL:

Battery: All batteries in the product and any accompanying accessories must be recycled separately. Batteries should be disposed of in accordance with local or national regulations.

Slings: Slings and associated material accessories should be sorted as combustible waste in accordance with local or national regulations.

17. Technical Specifications

	Manual	Electric
Safe Working Load (SWL).....	125kgs.....	125kgs
Highest position from base of seat.....	740mm.....	715mm
Lowest position from base of seat.....	140mm.....	140mm
Seat travel.....	485mm.....	485mm
Width of seat.....	Mermaid.....	450mm.....
	Commode.....	360mm.....
	Ranger.....	360mm.....
Width between arms.....	Mermaid.....	395mm.....
	Commode.....	395mm.....
	Ranger.....	430mm.....
Depth of seat (front to back).....	410mm.....	410mm
Centres between mast and seat.....	430mm.....	430mm
Maximum seat turning circle (side fit).....	Mermaid.....	850mm.....
	Commode.....	810mm.....
	Ranger.....	840mm.....
Maximum seat turning circle.....	Mermaid.....	865mm.....
	Commode.....	815mm.....
	Ranger.....	890mm.....
Minimum recommended clearance from mast to allow for leg room.....	1000mm.....	1000mm

WEIGHTS

Mermaid.....	28.8kgs.....	33.0kgs
Ranger.....	39.9kgs.....	44.0kgs
Battery pack.....	N/A.....	4.0kgs

TRANSPORTER (RANGER ONLY)

Maximum width.....	610mm
Maximum depth.....	560mm
Maximum height.....	610mm
Seat height.....	510mm
Seat to footrest (adjustable).....	430 - 480mm

Electrical Specification:

Batteries	2 x 12 VDC Rechargeable, sealed, lead acid gel
Capacity.....	3.2 Ampere/hours
Charger rated input.....	110 - 230Vac 50/60 Hz
Charger rated output	27.4/29.0 VDC@0.8A
Fuse - Lift.....	25A Fast Blow 1/4" x 1 1/4"

Electric Shock Protection

Charger - Class II Double Insulated

Lift - Internal Power Source

Degree of Shock Protection

Charger - Type B

Lift - Type B

Mode of operation - 15% Intermittent Duty

KEY SYMBOLS:

The following symbols are used on the charger, control unit and battery:



This product is a Medical Device in accordance with EU Medical Device Regulation 2017/745.



Class 2 equipment.

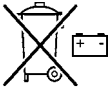

The disposal of batteries should not be mixed with general household waste. Batteries should be disposed of in accordance with local or national regulations.



The disposal of electronics should not be mixed with general household waste.



For indoor use.



ATTENTION, consult accompanying documents.



Refer to the user instructions before use.

18. Warranty

Joerns Healthcare has an established network of authorised distributors and service agents who will be pleased to handle all of your purchasing, warranty, repair and maintenance enquiries. It is recommended that our products are commissioned by your authorised distributor or service agent.

The distributor or service agent operates the warranty programme, so it is important to keep a record of their name, address and telephone number so they can be contacted should any problem arise. If you are in any doubt as to where your lift was purchased, Joerns Healthcare can trace the supplier if you quote the serial number of the lift.

All warranty claims are subject to the correct use and maintenance in accordance with the user instruction manual provided with each lift. Damage caused by use in unsuitable environmental conditions or failure to maintain the product in accordance with user and service instructions is not covered. Your statutory rights remain unaffected.

REMEMBER: Contact your authorised distributor or service agent for purchases, repairs, servicing and certified maintenance.

Your distributor: Easy Care Systems Ltd.



Joerns
Oxford®



Special Products and Service

Contact Us

Units 5 and 6 Lower Vicarage Road

Southampton

Hampshire

SO19 7RJ

T: 02380 420678

E: info@easycare systems.co.uk

www.easycare systems.co.uk