

# MOBI HD CHANGER

---

## INSTRUCTIONS FOR USE

Code 3161



| <b>CONTENTS</b>   | <b>PAGE</b> |
|---|-------------|
| 1.0 INTRODUCTION  | 1           |
| 2.0 ILLUSTRATION OF YOUR MOBI HEAVY DUTY CHANGER          | 2           |
| 3.0 TECHICAL DATA   | 3           |
| 4.0 FOR YOUR SAFETY                                       | 4           |
| 5.0 UNPACKING YOUR MOBI HEAVY DUTY CHANGER                | 5           |
| 6.0 SETTING UP AND ADJUSTING YOUR MOBI HEAVY DUTY CHANGER | 5           |
| 7.0 HOW TO USE YOUR MOBI HEAVY DUTY CHANGER               | 7           |
| 8.0 CARE & MAINTENANCE                                    | 8           |
| 9.0 WARRANTY & SERVICE                                    | 9           |
| 10.0 CONTINUOUS IMPROVEMENT                               | 9           |
| 11.0 SERVICE INSPECTION                                   | 10          |

## **1.0 INTRODUCTION**

Thank you for choosing the Smirthwaite Mobi Heavy Duty Changer.

The Mobi Heavy Duty Changer is a battery powered height adjustable changer specifically designed for heavy user weights. It has large under chassis clearance to allow access for heavy duty hoists and a large height range facilitating wheel chair transfers and a safe working environment for carers

The Mobi Heavy Duty Changer features an innovative protective skirt to prevent any contact with the lifting mechanism, and also is supplied with our unique stowaway side rails.

|   |   |
|---|---|
|  | <p><b>IMPORTANT!</b></p> <p>These instructions should be read by all therapists and carers using the equipment and should be retained for future reference. The product should always be used under adult supervision.</p>  |
|   | <p>Any incorrect use of the product and failure to follow the instructions may put the user at risk or impede the function. If you have any queries using this product or wish for further copies, please do not hesitate to contact Customer Service department on T: +44 (0)1626 835552</p> |

## 2.0 ILLUSTRATION OF YOUR MOBI HEAVY DUTY CHANGER



- A. Safety side
- B. Safety skirt
- C. Handset
- D. Battery
- E. Castors
- F. Emergency stop

The Mobi Heavy Duty Changer is supplied with 2 Batteries and a separate wall mounted mains powered charger unit as standard.

### 3.0 TECHNICAL DATA

| SIZE | TABLE DIMENSIONS |      | HEIGHT RANGE | USER WEIGHT | SAFETY SIDE |      |      | CASTOR |      | NOMINAL CLEARANCE | SHIPPING WEIGHT |
|------|------------------|------|--------------|-------------|-------------|------|------|--------|------|-------------------|-----------------|
|      | L mm             | W mm | H mm         | Kg          | X mm        | Y mm | Z mm | P mm   | Q mm | G mm              | Kg              |
| 1    | 2000             | 960  | 550-920      | 500         | 1050        | 165  | 200  | 1500   | 800  | 150               | 100             |

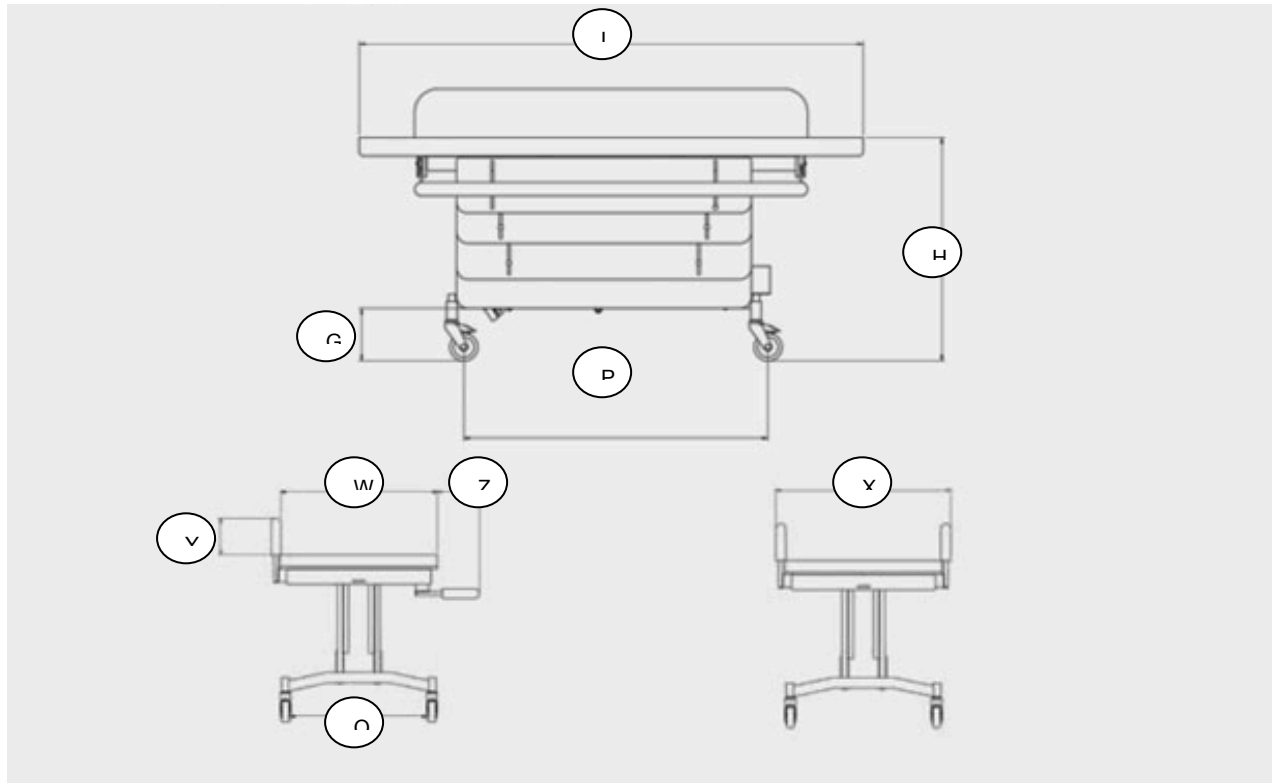

### 3.1 ELECTRICAL SPECIFICATION

|                   |                        |
|-------------------|------------------------|
| <b>Approvals:</b> |                        |
| Europe            | CE                     |
| USA/Canada        | UL                     |
| <b>System:</b>    |                        |
| Actuator          | Linak LA44 series 12KN |
| Control           | Linak CJB series       |
| Battery           | Linak BAJ series       |
| Handset           | Linak HB80 series      |
| Wall charger      | Linak CHJ series       |

## 4.0 FOR YOUR SAFETY

|   |  |
|---|--|
|  | <b>STOP!</b>   |
|   | <b>Please read these instructions CAREFULLY and THOROUGHLY</b> |

- The user should **NOT** be left unattended whilst in the changer. Always ensure a responsible therapist or carer is in attendance.
- The height should **NEVER** be adjusted without a carer in attendance.
- **Always** place the patient as centrally as possible on the bench.
- **DO NOT** locate the battery charging pack in a wet/damp environment.
- The changer should **NOT** be used as a transit system.
- Always keep this product away from naked flames, cigarettes and sources of heat including open fireplaces, radiators and heaters.
- Regular maintenance checks and cleaning are essential for the safe use of this equipment (see care and maintenance section).
- **DO NOT** fit parts or accessories of other manufacturers to this product unless authorised to do so in writing by Smirthwaite Ltd. Failure to follow these instructions will not only invalidate the guarantee but could make the product dangerous to use. Smirthwaite Ltd will not accept liability for any injury or damage incurred through such malpractices. Any repairs required must be carried out by Smirthwaite Ltd authorised personnel.
- If any part is loose, damaged or functioning incorrectly, **DO NOT** use until rectified.
- The Mobi Heavy Duty Changer is CE marked. This certifies that it meets all relevant European safety requirements.
- If you believe the product or any fitted accessory to be faulty at any time, **DO NOT USE** – contact Smirthwaite by telephone on +44 (0)1626 835552

|   |  |
|---|--|
|  | <b>IMPORTANT!</b>  |
|   | <b>For side transfers always ensure the safety side is in the fully stowed position. When the user has been transferred into the changer, please ensure safety sides are in the fully upright position and locked in place before use.</b> |

## 5.0 UNPACKING YOUR MOBI HEAVY DUTY CHANGER

|   |   |
|---|---|
|  | <b>STOP!</b>  |
|   | <p><b>Due to the weight of the changer, care should be taken with the initial handling – it is strongly recommended that two people lift the changer out its packaging.</b></p> |

- When delivered, the changer will be at its minimum height and the safety sides will be stowed under the bench.
- Please take note of any instructions on the packaging/box when unpacking.
- Place the changer on the floor with the castors locked.
- Check section 2.0 to confirm all parts/items have been delivered.
- If any part is loose, damaged or functioning incorrectly – do not use until rectified.

If you believe this product to be faulty **-DO NOT USE-**Contact Smirthwaite Ltd on T: +44 (0)1626 835552

## 6.0 SETTING UP AND ADJUSTING YOUR MOBI HEAVY DUTY CHANGER

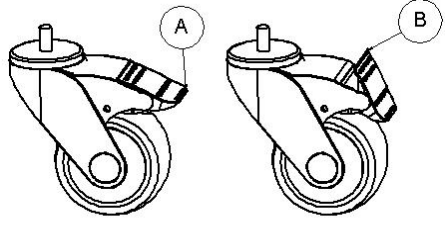
|   |   |
|---|---|
|  | <b>IMPORTANT!</b>   |
|   | <p><b>Always lock the castors when attaching items, or making adjustments. To lock, apply foot to point (A); to unlock, apply foot to point (B).</b></p> <div style="text-align: center;"><p>UNBRAKED      BRAKED</p></div> |

## 6.1 CHARGING YOUR MOBI HEAVY DUTY CHARGER

|   |   |
|---|---|
|  | <b>IMPORTANT!</b>   |
|   | <b>Each battery should be charged for at least 24 hours upon receipt by connecting the battery to the wall mounted charger.</b> |

- A green light will indicate that the charger is connected to the mains supply (the 'ON' lamp).
- A yellow light will indicate when a connected battery is being charged.
- For routine use, the battery should be removed from the charger and charged **daily**. The second supplied battery enables the changer to be used whilst the second battery is being charged.



## 6.2 HANDSET, CONTROL BOX AND EMERGENCY STOP/LOWER

|   |   |
|---|---|
|  | <b>IMPORTANT!</b>   |
|   | <b>Ensure you keep access the Emergency Stop button on the control box clear at all times. Be sure all equipment users are familiar with its location on the chassis.</b> |

- To raise or lower the changer bench, simply depress the 'Up' or 'Down' arrow on the handset.
- The control box and battery is sited on the changer bench chassis, at one end.
- The control box includes a red emergency stop button that can be depressed in the event of an emergency. If pressed, twist to reset once it is safe to do so.
- The control box emits an audible alarm when the battery is approaching the recharge point.
- If required, the bed can be lowered by pressing the 'down' arrow manually on the control box.



## 7.0 HOW TO USE YOUR MOBI HEAVY DUTY CHANGER

### 7.1 RAISING/LOWERING THE SAFETY SIDES

- Pull the safety side fully outwards (Z,Y)
- Swing it to the vertical position (X)
- Lift it up fully, and allow it to drop a small distance, locking it into the vertical position (X)
- Repeat for the second safety side

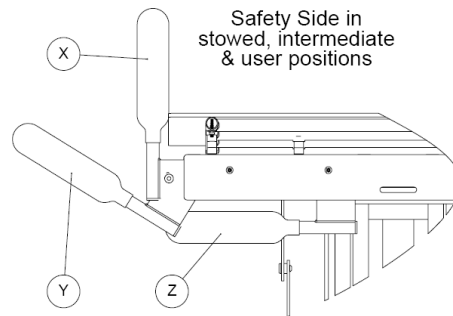

### 7.2 WHEELCHAIR TRANSFER

- Lift the safety side up and swing to horizontal position
- Stow the safety side under the table
- Lower the table to height of the wheelchair seat
- It is now possible to transfer the user onto the trolley

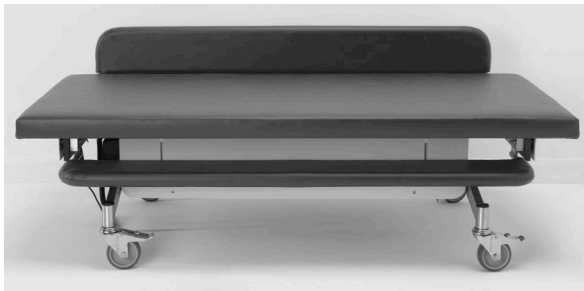

SAFETY SIDE DOWN



SAFETY SIDE UP



## 8.0 CARE AND MAINTENANCE

|   |   |
|---|---|
|  | <b>IMPORTANT!</b>                                 |
|   | <b>Cleaning is recommended on a regular basis</b> |

- To use a damp soft cloth with mild soap
- Rinse with clean cloth and water
- DO NOT use solvents, abrasives, synthetic detergents and wax polishes
- ALWAYS wipe dry after use
- ALWAYS keep this product away from naked flames, cigarettes and sources of heat including open fireplaces, radiators and heaters
- For further information please refer to MHRA or Local Authority cleaning guidelines

## 8.1 MAINTENANCE CHECKS

|  |  |
|--|--|
|  | <b>IMPORTANT!</b>                              |
|  | <b>Regular maintenance checks are required</b> |

### 8.1.1 DAILY CHECKS

- **CHECK THAT THE BATTERY IS FULLY CHARGED**
- Check all upholstery for signs of wear and tear
- Check the castors are running freely and brakes are in full working order
- Keep the upholstery, wooden and metal parts clean
- Check that all clamping and positional components are working, secure and free from damage

### 8.1.2 MONTHLY CHECKS

- Repeat daily checks
- Additionally, check all mechanical movements operate fully
- Additionally, check structure for signs of damage or wear and tear

## 8.2 SERVICE INTERVAL

The Mobi Heavy Duty Changer should be serviced every 1 year. Servicing must only be undertaken by a Smirthwaite service engineer, or by a Smirthwaite trained representative.

## 9.0 WARRANTY & SERVICE

Smirthwaite Ltd warrants the products detailed on your order to be free from defects in materials and workmanship for a period of 2 years from date of delivery. If a fault develops during the period, please call Customer Services by email or telephone 01626 835552 who will advise you on the best course of action. Possible action may be for us to arrange to send out one of our Service Engineers, or have the goods returned to us. Should a repair not be possible within the guarantee period we will replace the product for new or nearest equivalent product. In the unlikely event that we cannot repair or exchange we will refund in full.

This warranty is for the UK only. The warranty excludes faults due to accident, neglect, misuse, not following the Instructions and normal wear and tear. This warranty is in addition to your legal rights. Goods will only be collected from the original delivery address.

A charge may be made where the goods cannot be repaired under the terms of the warranty. You will be advised before this is made.

T: +44 (0)1626 835552 E: [info@smirthwaite.co.uk](mailto:info@smirthwaite.co.uk)

## 10.0 CONTINUOUS IMPROVEMENT

Smirthwaite Ltd are committed to continuous improvement to their product range. Should you have any suggestions or comments please send them to our product design department at: [info@smirthwaite.co.uk](mailto:info@smirthwaite.co.uk)

Smirthwaite Ltd reserve the right to change the specification or material without prior notice.





Special Products and Service

**Contact Us**

Units 5 and 6 Lower Vicarage  
Road  
Southampton  
Hampshire  
SO19 7RJ  
T: 02380 420678  
E: [info@easycare systems.co.uk](mailto:info@easycare systems.co.uk)

[www.easycare systems.co.uk](http://www.easycare systems.co.uk)